PC1142 Physics II

Stefan-Boltzmann's Law

1 Objectives

- Investigate the dependence of light intensity of a high temperature source of thermal radiation versus temperature of the source.
- Investigate the radiative property of surfaces at low temperature.

2 Equipment List

- Radiation Sensor
- Stefan-Boltzmann Lamp
- Thermal Radiation Cube
- Millivolt meter, digital multi meters and thermometer
- Power supply and meter stick

3 Theory

If an object is at temperature T and its surroundings are at temperature T_0 , then the net energy gained or lost by the object per unit time in the form of electromagnetic radiation is given by

$$P = \sigma A e (T^4 - T_0^4) \quad (1)$$

This is known as Stefan-Boltzmann's law where A is the surface area of the object and e is called the emissivity. The value of emissivity e depends on the properties of the surface and is defined as the ratio of energy radiated by the object to energy radiated by a blackbody at the same temperature T . A true blackbody has $e = 1$ while real objects have $e < 1$ since these will emit less radiation than an ideal blackbody. σ is called the Stefan-Boltzmann constant which can be expressed in terms of fundamental constants

$$\sigma = \frac{2\pi^5 k^4}{15c^2 h^3} = 5.669 \times 10^{-8} \text{ W/m}^2\text{K}^4 \quad (2)$$

where k is the Boltzmann's constant, c is the speed of light in vacuum and h is the Planck's constant.

4 Laboratory Work

Part A: Light Intensity versus Temperature

In this part of the experiment, you will make relative measurements of the power per unit area emitted from a hot object, namely the Stefan-Boltzmann Lamp, at various temperatures. From your data, you will be able to test whether the radiated power is really proportional to the fourth power of the temperature. The Stefan-Boltzmann Lamp, is a high temperature source of thermal radiation. The high temperature simplifies the analysis because the fourth power of the ambient temperature is negligibly small compared to the fourth power of the high temperature of the lamp filament.

- A-1. BEFORE TURNING ON THE LAMP, measure the room temperature in Kelvin and the resistance of the filament of the Stefan-Boltzmann Lamp at room temperature. Record them as T_{ref} and R_{ref} in Data Table 1.

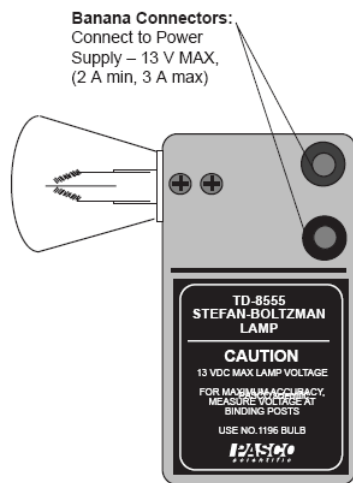

The Stefan-Boltzmann Lamp is a high temperature source of thermal radiation. By adjusting the power into the lamp (13 V max, 2 A min, 3 A max), filament temperatures up to approximately 3000°C can be obtained. The filament temperature is determined by carefully measuring the voltage and current into the lamp. The voltage divided by the current gives the resistance of the filament.

Figure 1: Stefan-Boltzmann Lamp.

- A-2. Set up the equipment as shown in Figure 2. The voltmeter should be connected directly to the binding posts of the Stefan-Boltzmann Lamp.

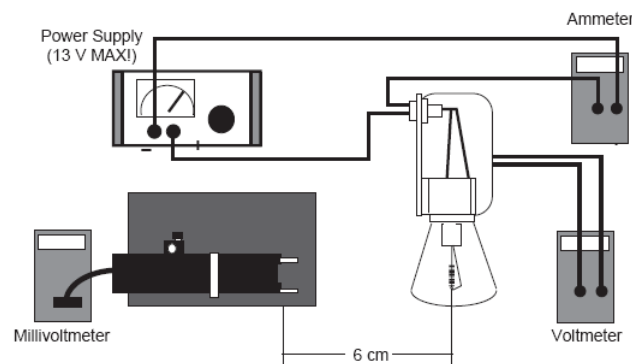

Figure 2: Equipment setup.

- A-3. Adjust the height of the Radiation Sensor so that it is at the same height as the filament with the front face of the sensor approximately 6 cm away from the filament (see Figure 2).

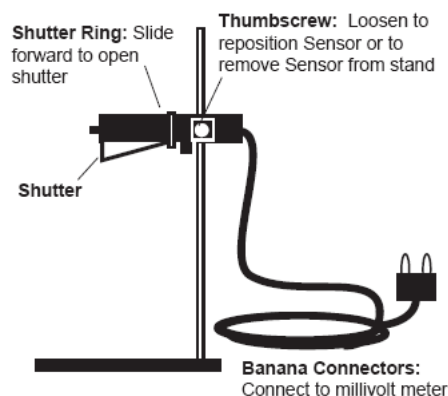

Figure 3: Radiation Sensor.

Note: The Radiation Sensor measures the relative intensities of incident thermal radiation. The sensing element, a miniature thermopile, produces a voltage proportional to the intensity of the radiation. The spectral response of the thermopile is essentially flat in the infrared region (from 0.5 to 40 μm) and the voltages produced range from the microvolt range up to around 100 millivolts. A spring-clip shutter is opened and closed by sliding the shutter ring forward or back. During experiments, the shutter should be closed when measurements are not actively being taken. This helps reduce temperature shift in the thermopile reference junction which can cause the sensor response to drift. The two posts extending from the front end of the sensor protect the thermopile and also provides a reference for positioning the sensor a repeatable distance from a radiation source.

- A-4. Make sure that the entrance angle of the thermopile should include no CLOSE objects other than the lamp.
- A-5. Turn on the power supply. Set the voltage V to each of the settings listed in Data Table 1. At each voltage setting, record the ammeter reading (current) as I and the reading on the millivolt meter as Rad in Data Table 3.

Note: Make each sensor reading quickly. Between readings, place both sheets of insulating foam between the lamp and the sensor, with the silvered surface facing the lamp, so that the temperature of the sensor stays relatively constant.

Part B: Radiative Property of Surfaces

In this part of the experiment, you will investigate Stefan-Boltzmann law at much lower temperatures with four different radiating surfaces: black, white, polished aluminium and dull aluminium. At these lower temperatures, the ambient temperature cannot be ignored.

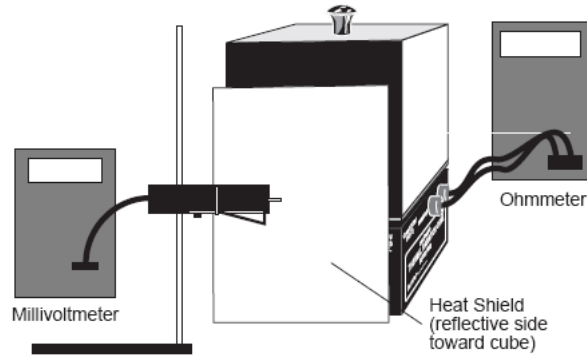
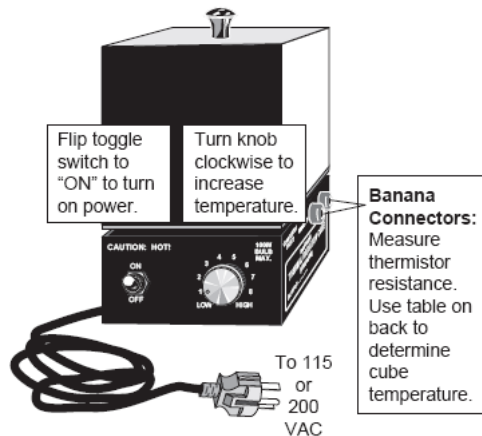

Figure 4: Equipment setup.

- B-1. Set up the equipment as shown in Figure 4. The Radiation sensor should be pointed directly at the center of the black surface. The fact of the sensor should be parallel with the surface of the cube and about 3 to 4 cm away.
- B-2. With the Thermal Radiation Cube off, measure the resistance of the thermistor at room temperature and record it as R_{rm} in Data Table 2.

CAUTION: Cube may be HOT!



The Thermal Radiation Cube provides four different radiating surfaces that can be heated from room temperature to approximately 120°C . The cube is heated by a 100 watt light bulb. Just plug in the power cord, flip the toggles with to "ON", then turn the knob clockwise to vary the power. The temperature of cube is determined via resistance measurement by plugging ohmmeter into the the banana plug connectors labeled THERMISTOR. The thermistor is embedded in one corner of the cube.

Figure 5: Thermal Radiation Cube.

- B-3. Shield the sensor from the cube using the reflecting heat shield with the reflective side of the shield facing the cube.

Note: As long as you are careful to shield the Radiation Sensor from the Thermal Radiation Cube when measurements are not being taken, the temperature of the sensor will be very close to room temperature.

- B-4. Turn on the Radiation Cube and set the power switch to 10.
- B-5. When the thermistor resistance indicated that the temperature is about 12°C above room temperature, turn the power down so the temperature is changing slowly. Read and record the ohmmeter reading as R and the millivolt meter reading as Rad in Data Table 2. The readings should be taken as nearly simultaneously as possible while briefly removing the heat shield.
- Note:** Make each reading quickly, removing the heat shield only as long as it takes to make the measurement. Take care that the position of the sensor with respect to the cube is the same for all measurements.
- B-6. Replace the heat shield and turn the cube power to 10. When the temperature has risen an additional $12\text{--}15^{\circ}\text{C}$, repeat the measurement of step B-5. Repeat this procedure at about $12\text{--}15^{\circ}\text{C}$ intervals until you have at least FIVE sets of data.
- B-7. Repeat the procedure for the other THREE surfaces and record your readings in Data Table 2.

A Stefan-Boltzmann Lamp

Temperature and Resistivity for Tungsten

$R/R_{300\text{K}}$	Temp $^{\circ}\text{K}$	Resistivity $\mu\Omega\text{ cm}$	$R/R_{300\text{K}}$	Temp $^{\circ}\text{K}$	Resistivity $\mu\Omega\text{ cm}$	$R/R_{300\text{K}}$	Temp $^{\circ}\text{K}$	Resistivity $\mu\Omega\text{ cm}$
1.0	300	5.65	7.14	1500	40.36	14.34	2700	81.04
1.43	400	8.06	7.71	1600	43.55	14.99	2800	84.70
1.87	500	10.56	8.28	1700	46.78	15.63	2900	88.33
2.34	600	13.23	8.86	1800	50.05	16.29	3000	92.04
2.85	700	16.09	9.44	1900	53.35	16.95	3100	95.76
3.36	800	19.00	10.03	2000	56.67	17.62	3200	99.54
3.88	900	21.94	10.63	2100	60.06	18.28	3300	103.3
4.41	1000	24.93	11.24	2200	63.48	18.97	3400	107.2
4.95	1100	27.94	11.84	2300	66.91	19.66	3500	111.1
5.48	1200	30.98	12.46	2400	70.39	26.35	3600	115.0
6.03	1300	34.08	13.08	2500	73.91			
6.58	1400	37.19	13.72	2600	77.49			

B Thermal Radiation Cube**Resistance versus Temperature**

Res. (Ω)	Temp. ($^{\circ}\text{C}$)	Res. (Ω)	Temp. ($^{\circ}\text{C}$)	Res. (Ω)	Temp. ($^{\circ}\text{C}$)	Res. (Ω)	Temp. ($^{\circ}\text{C}$)	Res. (Ω)	Temp. ($^{\circ}\text{C}$)
207,850	10	51,048	40	15,502	70	5,569.3	100	2,281.0	130
197,560	11	48,905	41	14,945	71	5,395.6	101	2,218.3	131
187,840	12	46,863	42	14,410	72	5,228.1	102	2,157.6	132
178,650	13	44,917	43	13,897	73	5,066.6	103	2,098.7	133
169,950	14	43,062	44	13,405	74	4,910.7	104	2,041.7	134
161,730	15	41,292	45	12,932	75	4,760.3	105	1,986.4	135
153,950	16	39,605	46	12,479	76	4,615.1	106	1,932.8	136
146,580	17	37,995	47	12,043	77	4,475.0	107	1,880.9	137
139,610	18	36,458	48	11,625	78	4,339.7	108	1,830.5	138
133,000	19	34,991	49	11,223	79	4,209.1	109	1,781.7	139
126,740	20	33,591	50	10,837	80	4,082.9	110	1,734.3	140
120,810	21	32,253	51	10,467	81	3,961.1	111	1,688.4	141
115,190	22	30,976	52	10,110	82	3,843.4	112	1,643.9	142
109,850	23	29,756	53	9,767.2	83	3,729.7	113	1,600.6	143
104,800	24	28,590	54	9,437.7	84	3,619.8	114	1,558.7	144
100,000	25	27,475	55	9,120.8	85	3,513.6	115	1,518.0	145
95,447	26	26,409	56	8,816.0	86	3,411.0	116	1,478.6	146
91,126	27	25,390	57	8,522.7	87	3,311.8	117	1,440.2	147
87,022	28	24,415	58	8,240.6	88	3,215.8	118	1,403.0	148
83,124	29	23,483	59	7,969.1	89	3,123.0	119	1,366.9	149
79,422	30	22,590	60	7,707.7	90	3,033.3	120	1,331.9	150
75,903	31	21,736	61	7,456.2	91	2,946.5	121		
72,560	32	20,919	62	7,214.0	92	2,862.5	122		
69,380	33	20,136	63	6,980.6	93	2,781.3	123		
66,356	34	19,386	64	6,755.9	94	2,702.7	124		
63,480	35	18,668	65	6,539.4	95	2,626.6	125		
60,743	36	17,980	66	6,330.8	96	2,553.0	126		
58,138	37	17,321	67	6,129.8	97	2,481.7	127		
55,658	38	16,689	68	5,936.1	98	2,412.6	128		
53,297	39	16,083	69	5,749.3	99	2,345.8	129		

Last updated: Friday 8th August, 2008 5:08am (KHCM)